

# WSA-00045 Dual Band Duplexer

## ◆ Description:

The WSA-00045 is a dual band duplexer which allows for simplified dual band handset testing, or can be used in dual band base station applications. The assembly contains two duplexers. The first provides AMPS band coverage of 824 to 849 MHz and 869 to 894 MHz. The second provides PCS band coverage of 1850 to 1910 MHz and 1930 to 1990 MHz (receive and transmit bands respectively). Each similar function port (for example, Rx-Rx, Tx-Tx, and Antenna to Antenna) are multiplexed together to provide the customer with single receive, transmit and antenna ports for integration to test systems.



## ◆ Specifications:

Receive Passbands:		Passband Return Loss:	12 dB min.
AMPS	824-849 MHz	Maximum Power Handling:	
PCS	1850-1910 MHz	CW	100 watts
		Peak Instantaneous	500 watts
Transmit Passbands:		Operating Temperature:	0 to +50°C
AMPS	869-894 MHz		
PCS	1930-1990 MHz	Storage Temperature:	-40°C to +85°C
Passband Insertion Loss:	1.0 dB max.	Operating Humidity:	0 to 90%, non-condensing
Passband Ripple:	0.8 dB p-p max.	Dimensions:	10.10"L x 4.60"W x
Antenna to Receive Rejection:		2.40"H	
DC-780 MHz	40 dB min.	(excluding connectors)	[256.5 x 116.8 x
869-1790 MHz	40 dB min.	61.0mm]	
1930-3000 MHz	40 dB min.	Connectors:	N-F (x3)
Transmit to Antenna Rejection:			
DC-849 MHz	40 dB min.		
935-1910 MHz	40 dB min.		
2050-3000 MHz	40 dB min.		
Isolation:			
Rx Passband(s) to Tx Passband(s)	40 dB min.		
Tx Passband(s) to Rx Passband(s)	40 dB min.		

Filtering Solutions for Your Global Market

### USA

Phone: 410-749-2424  
FAX: 410-749-5725  
Email: sales@klmicrowave.com

### EUROPE

Phone: +44-(0)-1908-547920  
FAX: +44-(0)-1908-695284  
Email: sales@kleurope.com

Order On-Line @ [www.klmicrowave.com](http://www.klmicrowave.com)



# WSA-0045 Dual Band Duplexer

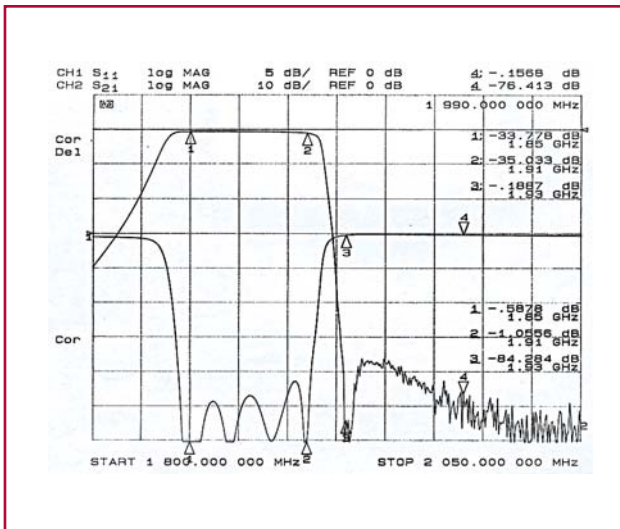

**AMPS Filters**

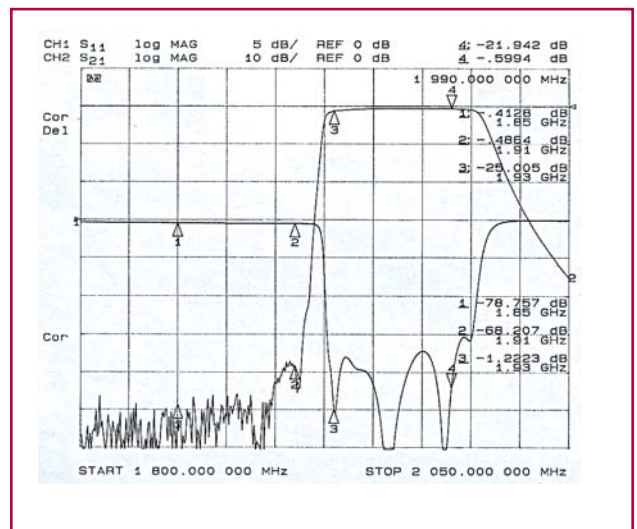

**PCS Filters**

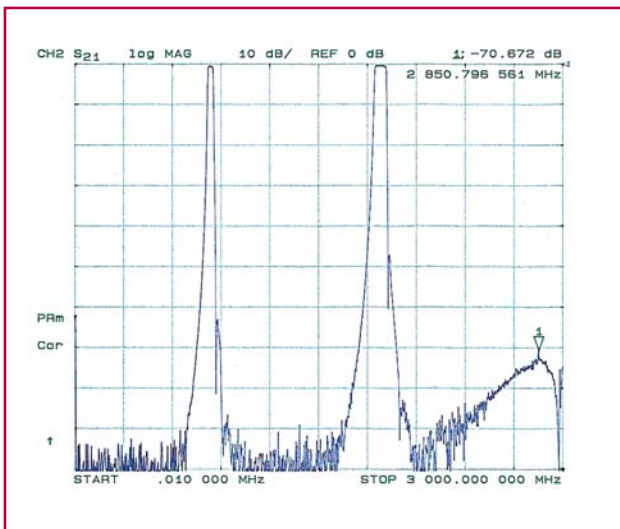

**Receive Port**

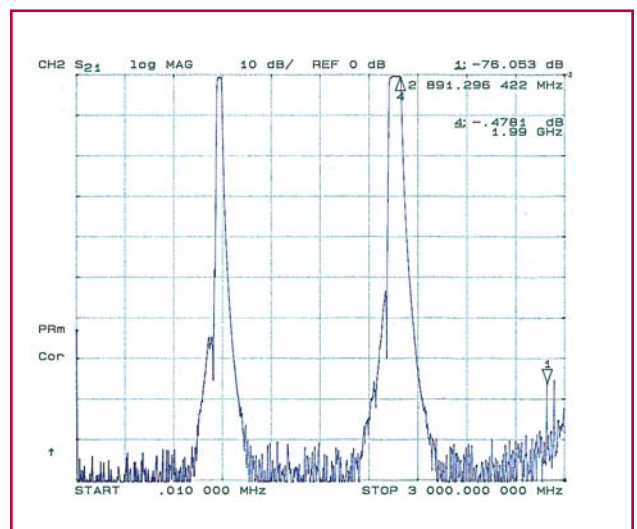

**Transmit Port**

**Filtering Solutions for Your Global Market**

**USA**

Phone: 410-749-2424  
 FAX: 410-749-5725  
 Email: sales@klmicrowave.com

**EUROPE**

Phone: +44-(0)-1908-547920  
 FAX: +44-(0)-1908-695284  
 Email: sales@kleurope.com

**Order On-Line @ [www.klmicrowave.com](http://www.klmicrowave.com)**



# WSA-00045 Dual Band Duplexer

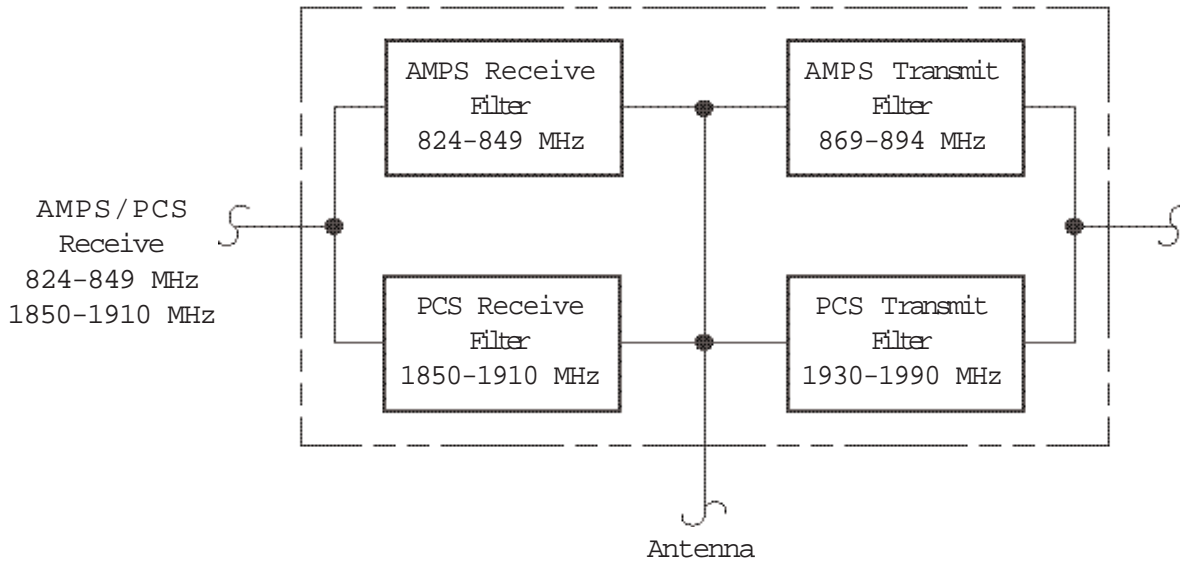

## WSA-00045 Dual Band Duplexer

Filtering Solutions for Your Global Market

### USA

Phone: 410-749-2424  
FAX: 410-749-5725  
Email: sales@klmicrowave.com

### EUROPE

Phone: +44-(0)-1908-547920  
FAX: +44-(0)-1908-695284  
Email: sales@kleurope.com

Order On-Line @ [www.klmicrowave.com](http://www.klmicrowave.com)

