

MAXI-X-X-X-SMA, 1.5 MHz – 1 GHz¹, 1 Watt, Tunable Filter MAXI-POLE®

Typical Applications

- Applications where small size, high power, and high performance are required
- Military Radios
- Military Radar
- SATCOM
- Test and Measurement Equipment
- Industrial and Medical Equipment

Features

- Up to +30 dBm CW continuous in-band power handling Error! Bookmark not defined.
- Up to +37 dBm CW continuous out-of-band power handling²
- +40 dBm IIP3 typical²
- 10 μ s typical tune time³
- Up to 70 dB typical ultimate selectivity at $(2 \times f_c)^2$
- Insertion loss as low as 1.2 dB²

Functional Diagram

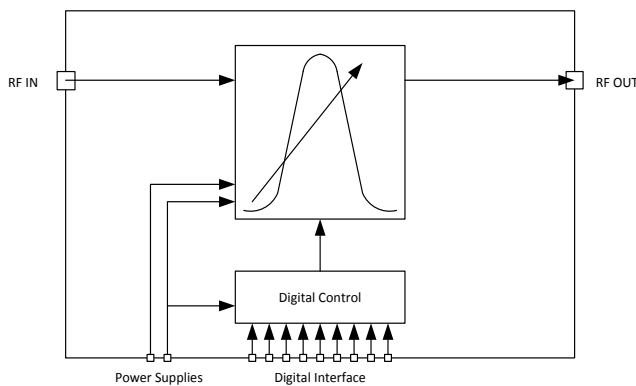

Description

The MAXI-POLE® series of filters is a series of digitally tunable bandpass filters with several standard designs in various tunable ranges to support a myriad of applications. The MAXI-POLE is optimized for RF power handling, low distortion, and exceptional selectivity. The MAXI-POLE comes in a 3.25 x 2.5 x 1.5 inch enclosure (82.55 x 63.5 x 38.1 mm) with convenient SMA connectors and 15-Pin D-connector for easy installation.

The MAXI-POLE® uses a high quality pin diode switched capacitor array with a customized high voltage driver to accurately and reliably tune to pre-defined frequencies. The MAXI-POLE is primarily used in applications where adjacent radio channels may cause interference on the acquisition channel. The MAXI-POLE can be used to reduce or eliminate the effects of these interfering signals, but it is flexible enough to be used in a multitude of applications.

The MAXI-POLE® uses an 8-bit wide proprietary parallel or serial interface to tune to a maximum of 251 tune positions per band. The MAXI-POLE will typically tune in less than 10 μ s³. The MAXI-POLE requires two external power supplies, +5 V and +100 V. However, an internal +100 V power supply can be provided requiring only a +5 V input.

All MAXI-POLE® filters are fully aligned and tested by POLE/ZERO® for convenience and ease of use. The MAXI-POLE covers eleven frequency ranges and custom configurations and designs are available upon request.



¹ Frequency range is in multiple filter bands.

² This specification depends on frequency and bandwidth.

³ For frequency bands where $f_0 > 90$ MHz at a +10 dBm reference.

1.0 Ordering Information

Table 1. Ordering Options

Series	Frequency Range (MHz)	Suffix (IL)	Connector Type	Options
MAXI	1.5-4	1 2 3 4 5	SMA	A B F
	4-10			
	10-30			
	30-90			
	90-200			
	200-400			
	225-400			
	225-450			
	225-512			
	400-700			
700-1000				

Table 2. Available Options

Option Code	Description
	If no options are specified, MAXI-POLE will be the standard parallel interface with a non-filtered, 15-pin D-Connector
A	Internal DC-DC Converter (Eliminates need for high voltage supply. Requires additional 100 mA of +5 VDC current)
B	Serial interface
F	Filtered D-Connector
C	Custom frequency bands (specify START and STOP frequencies in MHz)

Note: Options may be limited to particular frequency bands and/or configurations. Consult Pole/Zero for your application.

Example product number: MAXI-30-90-3-SMA, MAXI-200-400-5-SMA-AF

2.0 Block Diagram

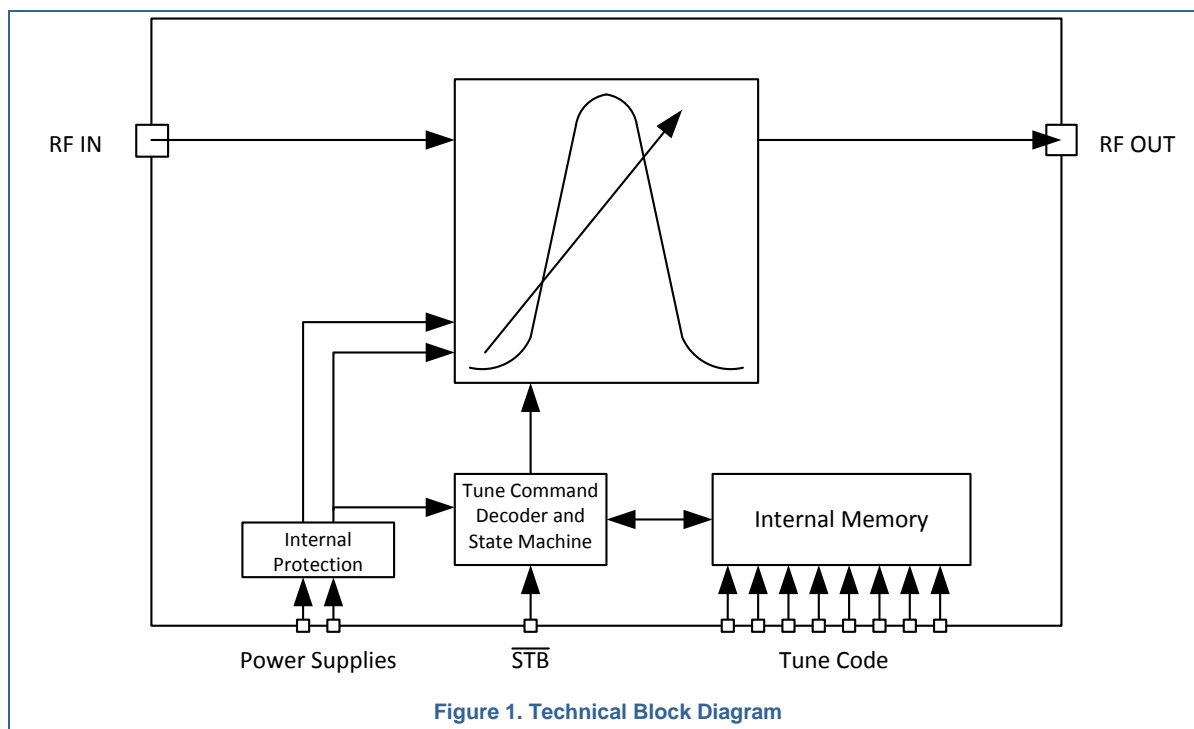

3.0 Pinout and Functional Information

3.1 Pinout/Description

Table 3. Parallel Interface

Pin Number	REF DES	Description	Max Ratings
1	A2	Tune Bit 2	+6 VDC
2	A3	Tune Bit 3	
3	A4	Tune Bit 4	
4	A5	Tune Bit 5	
5	A6	Tune Bit 6	
6	A7	Tune Bit 7 (MSb)	
7	GND	Ground	
8	Vcc	+5 VDC, +-10%	+6 VDC
9	GND	Ground	
10	Vbb	High Bias	+115 VDC
11	GND	Ground	
12	GND	Ground	
13	\overline{STB}	Strobe	
14	A0	Tune Bit 0 (LSb)	+6 VDC
15	A1	Tune Bit 1	

Table 4. Serial Interface

Pin Number	REF DES	Description	Max Ratings
1	SDO	Serial Data Out	+6 VDC
2	-	No Connect	
3	-	No Connect	
4	-	No Connect	
5	-	No Connect	
6	-	No Connect	
7	GND	Ground	
8	Vcc	+5 VDC, +-10%	+6 VDC
9	GND	Ground	
10	Vbb	High Bias	+115 VDC
11	GND	Ground	
12	GND	Ground	
13	\overline{STB}	Strobe	+6 VDC
14	SCLK	Serial Clock	
15	SDI	Serial Data In	

4.0 Specifications

4.1 Absolute Maximum Ratings⁴

Voltages are referenced to GND (ground = 0 V). Operating at room temperature (unless otherwise noted).

Symbol	Parameter	Conditions	Min	Max	Unit
V_{CC}	Supply voltage	-	-0.5	+6.0	V
V_{BB}	High supply voltage	-	-	+115	V
V_I	Input voltage on digital interface pins	Parallel Interface	-0.6	+6.0	V
		Serial Interface	-0.5	$V_{CC} + 0.5$	
V_O	Output voltage	On all digital interface output pins	-0.5	$V_{CC} + 0.5$	V
P_{INBAND}	In-band RF input power level	Signal is in passband $f_0 = 1.5 - 1000 \text{ MHz}^5$	-	33^6	dBm
$P_{OUTBAND}$	Out-of-band RF input power level	-	-	37^6	dBm
T_{RATE}	Maximum tune rate (frequency hopping)	1.5 - 4	-	0.170	kHz
		4 - 10		0.840	
		10 - 30		1.5	
		30 - 90		1.8	
		90 - 200		2	
		200 - 400			
		225 - 400			
		225 - 450			
225 - 512					
400 - 700					
700 - 1000					

⁴ Maximum operating conditions before damage occurs.

⁵ Frequency range is in multiple bands.

⁶ This specification depends on frequency and bandwidth.

4.2 Handling Ratings

Symbol	Parameter	Conditions	Min	Max	Unit
T_S	Storage temperature	-	-40	+85	°C

4.3 Recommended Operating Conditions

Symbol	Parameter	Conditions	Min	Nom	Max	Unit
V_{CC}	Supply voltage	-	4.5	5	5.5	V
V_{BB}	High supply voltage	-	90	100	110	V
P_{IN}	Maximum RF input power for linear operation	Signal is in passband	-	-	30 ⁶	dBm
T_A	Ambient temperature	-	-40	-	+85	°C

4.4 Electrical Characteristics

All specifications at $T_A = 23\text{ °C}$, $V_{CC} = +5\text{ V}$, $V_{BB} = +100\text{ V}$, unless otherwise noted.

Symbol	Parameter	Conditions	Min	Nom	Max	Unit
I_{CC_STATIC}	V_{CC} current consumption, statically tuned	At nominal V_{CC} voltage	-	80	250	mA
I_{CC_HOP}	V_{CC} current consumption, hopping	Nominal V_{CC} , hopping at 2 kHz ⁶	-	80	250	mA
I_{BB_STATIC}	V_{BB} current consumption, statically tuned	At nominal V_{BB} voltage	-	1	3	mA
I_{BB_HOP}	V_{BB} current consumption	Nominal V_{BB} , hopping at 1000 Hz	-	9 ⁷	-	mA
V_{IH}	Digital high level input voltage on all digital interface pins except \overline{STB}	Parallel Interface	2.0	-	-	V
		Serial Interface (-B)	$0.7 * V_{CC}$			
	Digital high level input voltage on \overline{STB} pin	All interfaces	$0.7 * V_{CC}$			
V_{IL}	Digital low level input voltage on all digital interface pins except \overline{STB}	Parallel interface	-	-	0.8	V
		Serial interface (-B)			$0.3 * V_{CC}$	
	Digital low level input voltage on \overline{STB} pin	All interfaces			$0.3 * V_{CC}$	
I_L	Digital interface pin leakage current on all interface pins	-	-	-	10	μA
V_{OH}	Digital high level output for serial interface (-B)	$I_{OH} = -400\text{ μA}$	2.4	-	-	V
V_{OL}	Digital low level output for serial interface (-B)	$I_{OL} = 2.1\text{ mA}$	-	-	0.4	V
Z_O	Input/output impedance	-	-	50	-	Ω
VSWR	Voltage Standing Wave Ratio	-	-	See Selection Guide	-	-
F_{DRIFT}	Center frequency drift over temperature	-40 to +85 °C	-	-	-80	ppm/°C
Weight	Weight of unit	-	-	12	-	oz

⁷ I_{BB_HOP} is dependent upon frequency of filter and hop rate. Lower frequency ranges will have higher dynamic current.

4.5 Selection Guide:

Band	Suffix	3 dB %BW		Insertion Loss (IL) (dB)		Return Loss (dB)		Shape Factor Overall $\left(\frac{30 \text{ dB}}{3 \text{ dB}}\right)$		Selectivity ($f_0 \pm 10\%$) (dB)		Ultimate Selectivity ($2 * f_0$) (dB) ⁸	IIP3 (dB)	Noise Figure (dB)		
		Avg	Max	Avg	Max	Avg	Min	Avg	Max	Avg	Min	Typical	Avg	Avg	Max	
1.5 - 4	-															
	-1													IL	IL \pm 1dB	
	-2	5.1	5.5	1.6	2.3	14	9.5	6.4	7.0	25	22	55	30	IL	IL \pm 1dB	
	-3													IL	IL \pm 1dB	
	-4													IL	IL \pm 1dB	
4 - 10	-5	2.0	2.2	4.2	6.3	12	9.5	6.5	7.0	42	38	60	30	IL	IL \pm 1dB	
	-1													IL	IL \pm 1dB	
	-2	5.3	5.5	1.8	2.3	14	9.5	6.3	7.0	25	22	55	40	IL	IL \pm 1dB	
	-3	3.4	3.9	2.2	3.5	14	9.5	6.4	7.0	30	27	55	40	IL	IL \pm 1dB	
	-4													IL	IL \pm 1dB	
10 - 30	-5	2.0	2.2	3.8	6.3	12	9.5	6.5	7.0	42	38	60	35	IL	IL \pm 1dB	
	-1													IL	IL \pm 1dB	
	-2	5.0	5.5	1.5	2.3	14	9.5	6.3	7.0	25	22	55	45	IL	IL \pm 1dB	
	-3	3.6	3.9	2.0	3.5	14	9.5	6.3	7.0	30	27	55	40	IL	IL \pm 1dB	
	-4	2.4	2.8	3.5	4.5	14	9.5	6.4	7.0	36	33	60	35	IL	IL \pm 1dB	
30 - 90	-5	2.0	2.2	3.8	6.3	12	9.5	6.4	7.0	43	40	60	35	IL	IL \pm 1dB	
	-1													IL	IL \pm 1dB	
	-2													IL	IL \pm 1dB	
	-3	3.5	3.9	2.5	3.5	14	10	6.3	7.0	30	27	60	40	IL	IL \pm 1dB	
	-4	2.6	2.8	3.5	4.5	16	10	6.3	7.0	36	33	70	35	IL	IL \pm 1dB	
90 - 200	-5	2.0	2.2	4.0	6.3	12	8	6.5	7.0	43	40	70	35	IL	IL \pm 1dB	
	-1													IL	IL \pm 1dB	
	-2													IL	IL \pm 1dB	
	-3	3.6	3.9	2.0	3.5	14	10	6.3	7.0	30	27	60	40	IL	IL \pm 1dB	
	-4	2.5	2.8	2.8	4.5	14	10	6.4	7.0	36	33	70	35	IL	IL \pm 1dB	
200 - 400	-5	2.0	2.2	3.5	6.3	14	10	6.3	7.0	43	40	70	35	IL	IL \pm 1dB	
	-1	10.0	10.9	0.8	1.2	16	10	6.1	7.0	12	10	60	50	IL	IL \pm 1dB	
	-2	5.0	5.5	1.6	2.3	14	10	6.1	7.0	25	22	60	45	IL	IL \pm 1dB	
	-3	3.4	3.9	2.0	3.5	14	10	6.2	7.0	30	27	60	40	IL	IL \pm 1dB	
	-4	2.5	2.8	2.8	4.5	14	10	6.3	7.0	36	33	70	35	IL	IL \pm 1dB	
225 - 400	-5	1.9	2.2	4.2	6.3	12	8	6.3	7.0	43	40	70	35	IL	IL \pm 1dB	
	-1	10.0	10.9	0.7	1.2	16	10	6.1	7.0	12	10	60	50	IL	IL \pm 1dB	
	-2	5.0	5.5	1.5	2.3	14	10	6.1	7.0	25	22	60	45	IL	IL \pm 1dB	
	-3	3.4	3.9	1.9	3.5	14	10	6.2	7.0	30	27	60	40	IL	IL \pm 1dB	
	-4	2.5	2.8	2.7	4.5	14	10	6.3	7.0	36	33	70	35	IL	IL \pm 1dB	
	-5	1.9	2.2	4.1	6.3	12	8	6.3	7.0	43	40	70	35	IL	IL \pm 1dB	

⁸ Typical performance, ultimate selectivity is not guaranteed.



Band	Suffix	3 dB %BW		Insertion Loss (IL) (dB)		Return Loss (dB)		Shape Factor Overall (30 dB / 3 dB)		Selectivity (f ₀ ± 10%) (dB)		Ultimate Selectivity (2 * f ₀) (dB) ⁹	IIP3 (dB)	Noise Figure (dB)		
		Avg	Max	Avg	Max	Avg	Max	Avg	Max	Avg	Min	Typical	Avg	Avg	Max	
225 - 450	-															
	-1														IL	IL ± 1dB
	-2														IL	IL ± 1dB
	-3	3.5	3.9	2.0	3.5	12	10	6.3	7.0	30	27	60	40	IL	IL ± 1dB	
	-4														IL	IL ± 1dB
225 - 512	-5														IL	IL ± 1dB
	-1														IL	IL ± 1dB
	-2														IL	IL ± 1dB
	-2.5	3.9	4.5	2.3	3.5	14	10	6.3	7.0	27	24	60	40	IL	IL ± 1dB	
	-3														IL	IL ± 1dB
400 - 700	-4														IL	IL ± 1dB
	-5														IL	IL ± 1dB
	-1	9.8	10.5	0.8	1.5	14	9.5	6.5	7.0	12	10	50	50	IL	IL ± 1dB	
	-2	5.0	5.5	1.5	2.5	14	9.5	6.4	7.0	25	21	50	45	IL	IL ± 1dB	
	-3	3.5	3.9	2.8	3.8	12	9.5	6.5	7.0	30	27	50	40	IL	IL ± 1dB	
700 - 1000	-4	2.5	2.8	3.2	4.6	12	9.5	6.5	7.0	36	33	50	35	IL	IL ± 1dB	
	-5	2.0	2.2	4.5	6.5	12	9.5	6.5	7.0	43	40	50	35	IL	IL ± 1dB	
	-1														IL	IL ± 1dB
	-2	5.0	5.5	1.7	2.5	14	9.5	6.4	7.0	25	21	45	45	IL	IL ± 1dB	
	-3														IL	IL ± 1dB
700 - 1000	-4														IL	IL ± 1dB
	-5	1.9	2.2	4.8	6.5	12	9.5	6.5	7.0	43	40	45	35	IL	IL ± 1dB	

⁹ Typical Performance, ultimate selectivity is not guaranteed.

4.6 Typical Characteristics

The following plots illustrate approximate performance (not representative of all frequency ranges).

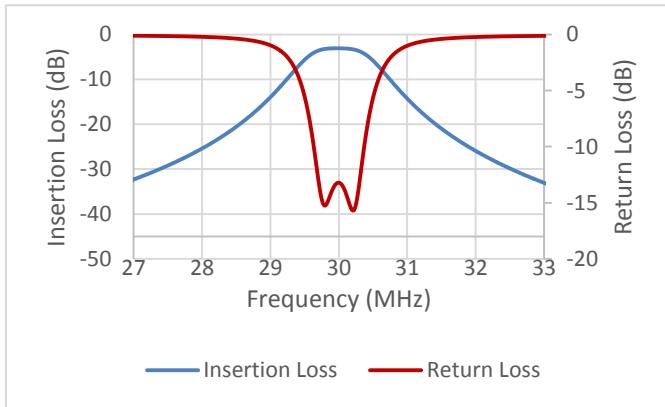

Figure 2. MAXI-30-90-3-SMA

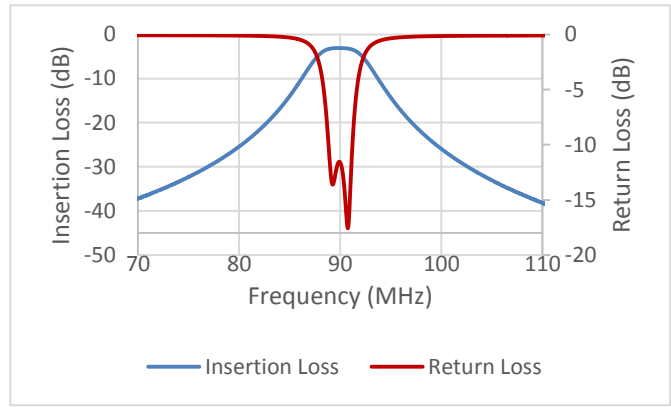

Figure 3. MAXI-30-90-3-SMA

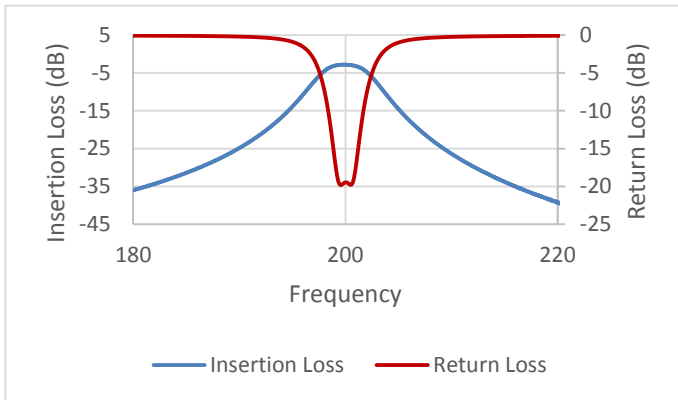

Figure 4. MAXI-200-400-4-SMA

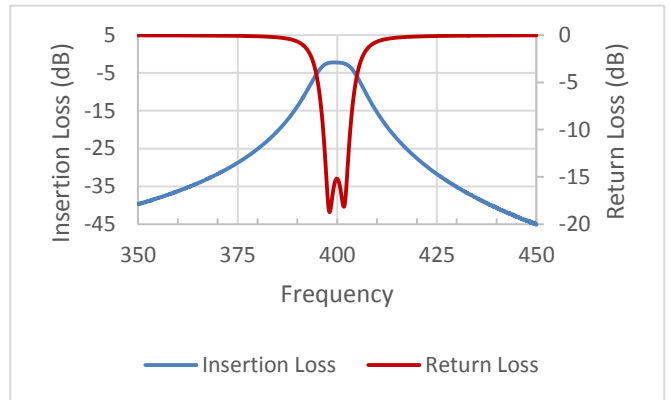

Figure 5. MAXI-200-400-4-SMA

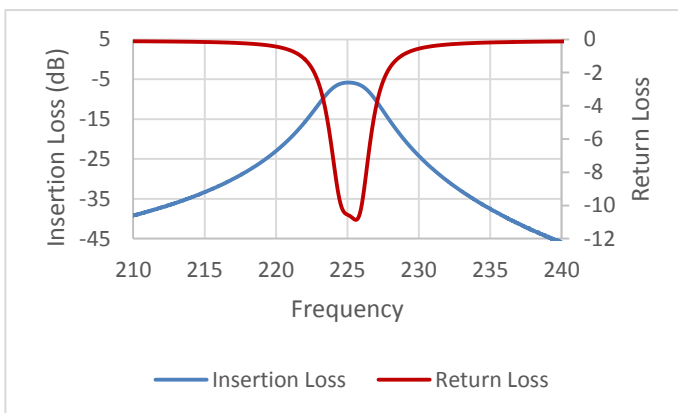

Figure 6. MAXI-225-400-7-SMP

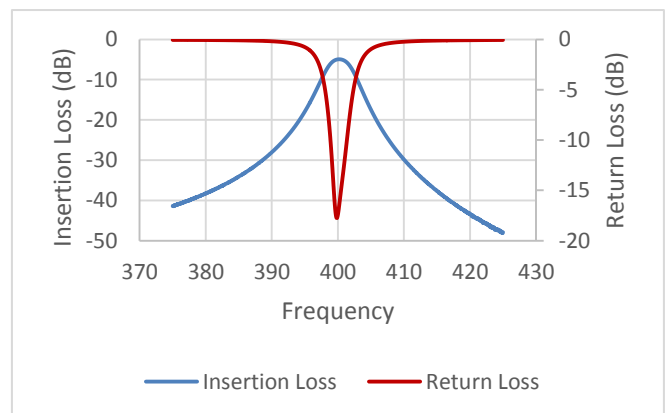

Figure 7. MAXI-225-400-7-SMP

4.7 Timing Requirements

4.7.1 Parallel Interface Timing

The parallel tune command interface is an 8-bit wide synchronous parallel interface with a single-byte load. There are always 8 data bits per parallel tune. A7 is the most significant bit and A0 is the least significant bit.

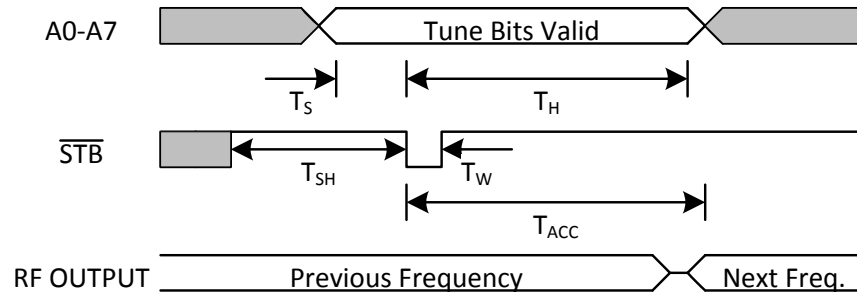

Figure 8. Parallel Timing Diagram

Table 5. SPI Timing Characteristics

$V_{CC} = 5.0\text{ V} \pm 10\%$, $GND = 0\text{ V}$

Symbol	Parameter	Min.	Max.	Unit
T_S	Setup Time – Minimum time from A0-A7 valid until the falling edge of \overline{STB} .	200	-	ns
T_H	Hold Time – Minimum time that the A0-A7 bits need to be held valid after \overline{STB} transitions low.	6	-	μs
T_{SH}	Strobe High Time – Minimum time \overline{STB} needs to be held high before the falling edge of \overline{STB} when initiating a tune event.	25	-	μs
T_W	Strobe Pulse Width – The amount of time \overline{STB} needs to be held low when initiating a tune event.	20	-	ns
T_{ACC}	Access Time – The amount of time from when \overline{STB} is brought low until the MAXI-POLE is tuned to the commanded frequency.	-	15^{10}	μs
T_{DW}	Dwell Time (not shown) – The amount of time between subsequent falling edges of \overline{STB} (this can also be considered the maximum hop rate).	500	-	μs

¹⁰ For frequency bands where $f_0 > 90\text{ MHz}$ at a +10 dBm reference. See section 7.0 Tune Time for additional information.

4.7.2 Serial Interface Timing

The serial tune command interface is a proprietary three-input and one-output interface. The inputs SDI, SCLK, and $\overline{\text{STB}}$ are used for loading the tune command into the MAXI-POLE while SDO shifts the last previously sent tune command out. Data is sent most significant bit (MSb) first and is clocked in on the rising edge of SCLK. After 8 subsequent SCLK rising edges, the tune command has been completely loaded into the MAXI-POLE and it is ready to be enabled by the $\overline{\text{STB}}$ pin transitioning low. For best operation, it is recommended that the SCLK signal remain low while not actively loading a tune command.

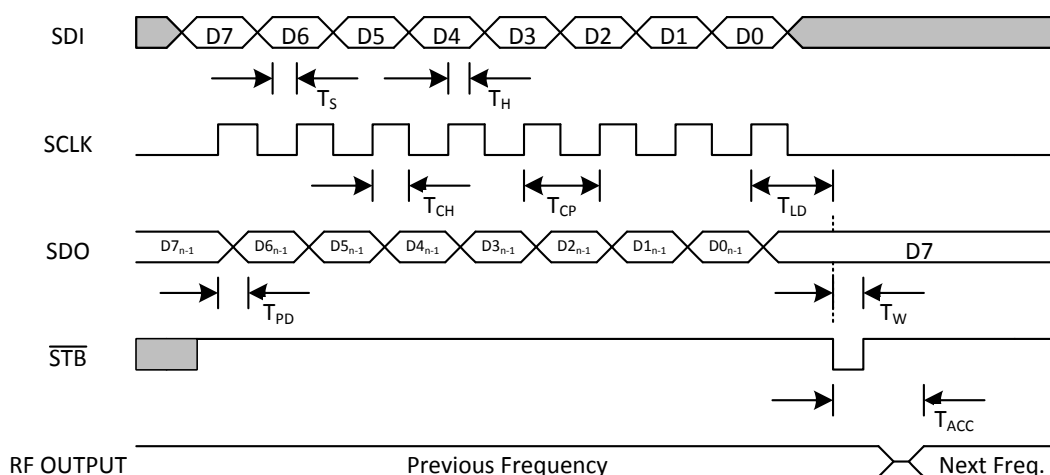

Figure 9. Serial Timing Diagram

Table 6. Parallel Timing Characteristics

$V_{CC} = 5\text{ V} \pm 10\%$, $GND = 0\text{ V}$

Symbol	Parameter	Min.	Max.	Unit
T_S	Setup Time – Minimum time that SDI needs to be stable before the rising edge of SCLK.	25	-	ns
T_H	Hold Time – Minimum time that SDI needs to be held valid after the rising edge of SCLK.	5	-	ns
T_{CH}	Clock High Time – Minimum amount of time the SCLK signal needs to be held high when loading data on the SDI pin.	41.667	-	ns
T_{CP}	Clock Pulse Width – The maximum clock rate at which the serial interface can run.	-	10	MHz
T_{LD}	Load Delay Time – Minimum amount of time required after the last rising edge of SCLK until the $\overline{\text{STB}}$ pin can transition low.	275	-	ns
T_{PD}	SDO Propagation Delay – The maximum amount of time after the rising edge of clock that the data on SDO will be valid.	-	50	ns
T_W	Strobe Pulse Width – The amount of time $\overline{\text{STB}}$ needs to be held low when initiating a tune event.	20	-	ns
T_{ACC}	Access Time – The amount of time from when $\overline{\text{STB}}$ transitions low until the MAXI-POLE is tuned to the commanded frequency.	-	15^{11}	μs

¹¹ For frequency bands where $f_0 > 90\text{ MHz}$ at a +10 dBm reference. See section 7.0 Tune Time for additional information.

5.0 Functional Description

5.1 Tune Commands

The tune command is a single-byte load tune command. The tune command specifies how many tune positions to offset from the MAXI-POLE's minimum frequency.

Table 7. Tune Command Properties

Symbol	Filter Freq. Range	Value	Description
f_{MIN}	See Table 8 for specific values		Minimum Tunable Frequency. f_{MIN} is the absolute minimum frequency that the MAXI-POLE is capable of tuning to for the respective band.
f_{MAX}			Maximum Tunable Frequency. f_{MAX} is the absolute maximum frequency that the MAXI-POLE is capable of tuning to.
f_{STEP}			Tune step size. f_{STEP} is the minimum spacing between adjacent tune commands.
f_{COM}	All	$\text{round}\left(\frac{(f_{DESIRED} - f_{MIN})}{f_{STEP}}\right)$	Commanded Frequency. f_{COM} is the commanded frequency that is sent over the SPI or parallel tune interface. The command can be calculated by subtracting f_{MIN} from the desired frequency for the particular band, dividing the result by the f_{STEP} of that band, and then rounding to the nearest command. The formula is used to select the closest possible frequency to the desired tune command. If the next lowest tune command is desired, replace the round operation with floor and if the next highest tune command is desired replace the round operation with ceil(ing).

Table 8. Tune Command Format

Tune Command Format (Bit Step Size in MHz)											
MAXI-POLE MODEL	f_{MIN} (MHz)	f_{MAX} (MHz)	f_{STEP} (kHz)	(MSb) 7	6	5	4	3	2	1	(LSb) 0
MAXI-1.5-4-X-SMA-X	1.5	4	10	1.28	0.64	0.32	0.16	0.08	0.04	0.02	0.01
MAXI-4-10-X-SMA-X	4	10	24	3.072	1.536	0.768	0.384	0.192	0.096	0.048	0.024
MAXI-10-30-X-SMA-X	10	30	80	10.24	5.12	2.56	1.28	0.64	0.32	0.16	0.08
MAXI-30-90-X-SMA-X	30	90	240	30.72	15.36	7.68	3.84	1.92	0.96	0.48	0.24
MAXI-90-200-X-SMA-X	90	200	440	56.32	28.16	14.08	7.04	3.52	1.76	0.88	0.44
MAXI-200-400-X-SMA-X	200	400	800	102.4	51.2	25.6	12.8	6.4	3.2	1.6	0.8
MAXI-225-400-X-SMA-X	225	400	700	89.6	44.8	22.4	11.2	5.6	2.8	1.4	0.7
MAXI-225-512-X-SMA-X	225	512	1148	146.944	73.472	36.736	18.368	9.184	4.592	2.296	1.148
MAXI-400-700-X-SMA-X	400	700	1200	153.6	76.8	38.4	19.2	9.6	4.8	2.4	1.2

Table 9. Special Tune Commands

Tune Code (Decimal)	Function
251 – 254	Blank mode – There will be high RF input-to-output isolation.
255	Power save mode – All PIN diodes will be turned off to conserve energy.

6.0 Detailed Description

6.1 Example Tune Commands

Table 10. Example Tune Commands

MAXI-POLE Band	$f_{DESIRED}$ (MHz)	f_{MIN} of Band (MHz)	f_{STEP} of Band (MHz)	f_{COM} Calculation (Decimal)	f_{COM} (Decimal)	f_{COM} (Hex)	f_{ACTUAL} (MHz)
1.5 - 4	1.5	1.5	0.01	$round\left(\frac{(1.5 - 1.5)}{0.01}\right)$	0	0x00	1.5
1.5 - 4	3.2	1.5	0.01	$round\left(\frac{(3.2 - 1.5)}{0.01}\right)$	170	0xAA	3.2
1.5 - 4	4	1.5	0.01	$round\left(\frac{(4 - 1.5)}{0.01}\right)$	250	0xFA	4
4 - 10	4	4	0.024	$round\left(\frac{(4 - 4)}{0.024}\right)$	0	0x00	4
4 - 10	7.65	4	0.024	$round\left(\frac{(7.65 - 4)}{0.024}\right)$	152	0x98	7.648
4 - 10	10	4	0.024	$round\left(\frac{(10 - 4)}{0.024}\right)$	250	0xFA	10
10 - 30	10	10	0.08	$round\left(\frac{(10 - 10)}{0.08}\right)$	0	0x00	10
10 - 30	22.3	10	0.08	$round\left(\frac{(22.3 - 10)}{0.08}\right)$	154	0x9A	22.32
10 - 30	30	10	0.08	$round\left(\frac{(30 - 10)}{0.08}\right)$	250	0xFA	30
30 - 90	30	30	0.24	$round\left(\frac{(30 - 30)}{0.24}\right)$	0	0x00	30
30 - 90	67.876	30	0.24	$round\left(\frac{(67.876 - 30)}{0.24}\right)$	158	0x9E	67.92
30 - 90	90	30	0.24	$round\left(\frac{(90 - 30)}{0.24}\right)$	250	0xFA	90
90 - 200	90	90	0.44	$round\left(\frac{(90 - 90)}{0.44}\right)$	0	0x00	90
90 - 200	120.76	90	0.44	$round\left(\frac{(120.76 - 90)}{0.44}\right)$	70	0x46	120.8
90 - 200	200	90	0.44	$round\left(\frac{(200 - 90)}{0.44}\right)$	250	0xFA	200
200 - 400	200	200	0.8	$round\left(\frac{(200 - 200)}{0.8}\right)$	0	0x00	200
200 - 400	317.8	200	0.8	$round\left(\frac{(317.8 - 200)}{0.8}\right)$	147	0x93	317.6
200 - 400	400	200	0.8	$round\left(\frac{(400 - 200)}{0.8}\right)$	250	0xFA	400
225 - 400	225	225	0.7	$round\left(\frac{(225 - 225)}{0.7}\right)$	0	0x00	225
225 - 400	299.9	225	0.7	$round\left(\frac{(299.9 - 225)}{0.7}\right)$	107	0x6B	229.9
225 - 400	400	225	0.7	$round\left(\frac{(400 - 225)}{0.7}\right)$	250	0xFA	400
225 - 512	225	225	1.148	$round\left(\frac{(225 - 225)}{1.148}\right)$	0	0x00	225
225 - 512	410.2	225	1.148	$round\left(\frac{(410.2 - 225)}{1.148}\right)$	161	0xA1	409.828
225 - 512	512	225	1.148	$round\left(\frac{(512 - 225)}{1.148}\right)$	250	0xFA	512
400 - 700	400	400	1.2	$round\left(\frac{(400 - 400)}{1.2}\right)$	0	0x00	400
400 - 700	503.4	400	1.2	$round\left(\frac{(503.4 - 400)}{1.2}\right)$	86	0x56	503.2
400 - 700	700	400	1.2	$round\left(\frac{(700 - 400)}{1.2}\right)$	250	0xFA	700

6.2 Additional Interface Detail

Table 11. Additional Pin Information

Pin Name	Description
VBB	High Bias Voltage – A bias voltage is required to reverse bias the PIN diodes used to tune the filter. Very little static current is needed for this bias voltage. While a minimum of +30 V is recommended for MAXI-POLE operation, using the recommended voltage for this power supply will increase power handling capability and reduce intermodulation significantly. See 4.3 Recommended Operating Conditions for recommended conditions for this supply. All MAXI-POLEs are tuned and aligned in the factory using the recommended operating voltages unless otherwise specified.
\overline{STB}	The filter is tuned on the falling edge of \overline{STB} . For parallel MAXI-POLEs, once the MAXI-POLE has completely tuned, data is ignored on the address pins until the next falling edge of \overline{STB} . Consult section 7.0 Tune Time for the maximum rate at which subsequent \overline{STB} events can be applied to the MAXI-POLE.

7.0 Tune Time

Tune times include internal processing of the tune command data and the 90% settled RF amplitude response time of the filter. This time excludes the time required to load the tune command into the filter. Low level signal measurements were utilized to show the tune time that can be expected at +10dBm.

In addition, RF power in excess of +20 dBm (+12 dBm for < 10 MHz) is considered to be “hot switching” of the filter, and the tuning operation of the filter at these levels cannot be done reliably. It is recommended that RF power be kept less than 20 dBm (+10 dBm for < 10MHz) during a tune event.

Table 12. Typical RF Tune Times

($T_A = 23\text{ }^\circ\text{C}$, $V_{CC} = +5\text{ V}$, $V_{BB} = +100\text{ V}$, Power Level = +10 dBm)

Freq. (MHz)		Catalog Part Number	Tune Time (μs)
From	To		
10	30	MAXI-10-30-3-SMA	27.2
30	10	MAXI-10-30-3-SMA	56.2
30	90	MAXI-30-90-5-SMA-AF	15.3
90	30	MAXI-30-90-5-SMA-AF	13.95
200	400	MAXI-200-400-5-SMA	9.72
400	200	MAXI-200-400-5-SMA	11.8
225	450	MAXI-225-450-3-SMA	11.75
450	225	MAXI-225-450-3-SMA	10.85

8.0 Package Information

8.1 Package Detail

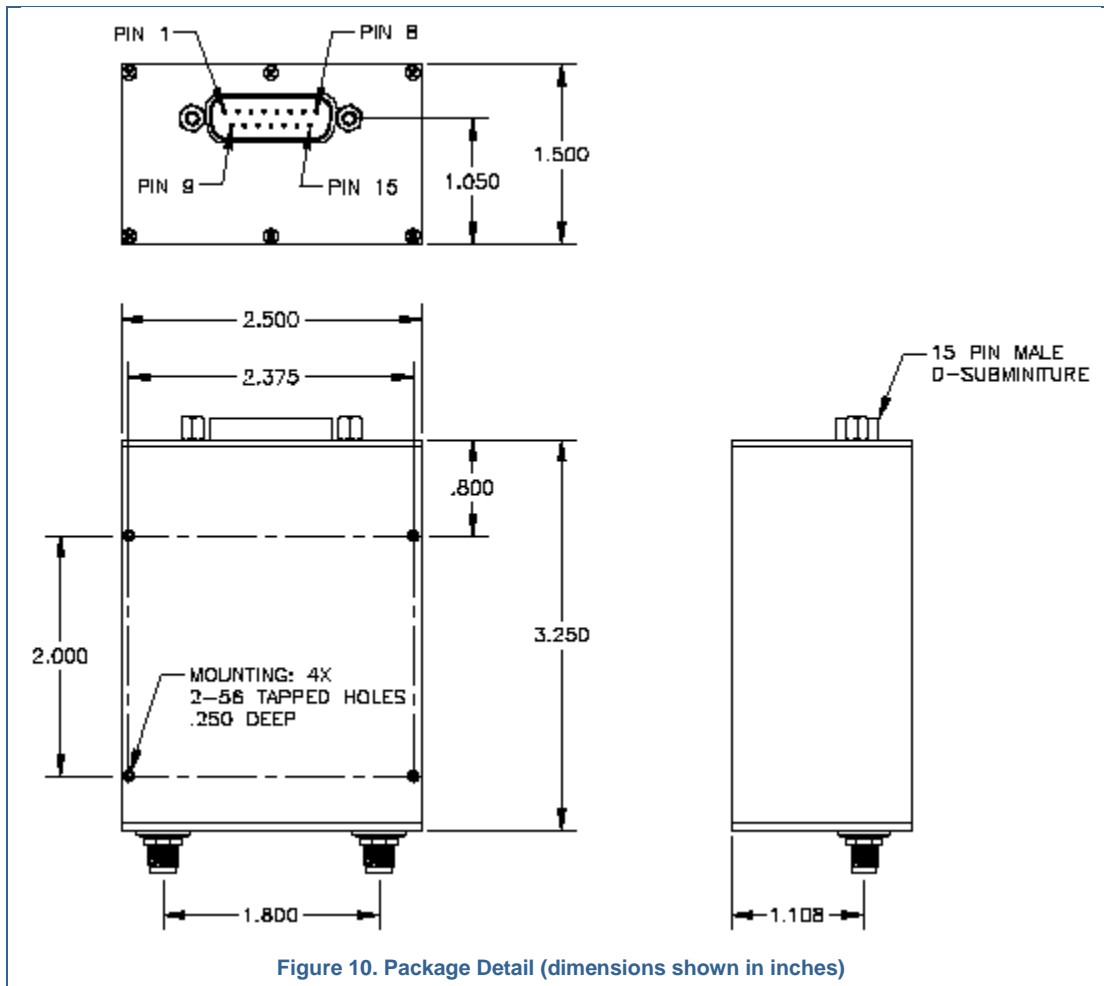

9.0 Safety Notes

9.1 Handling Information

Caution



This device contains electrostatic discharge sensitive devices and is sensitive to electrostatic discharge (ESD). Observe all precautions for handling electrostatic sensitive devices.

Caution



This device may produce potentially hazardous voltages. Take necessary precautions when handling this device while power is enabled.

10.0 Legal Information

10.1 Disclaimers

Limited warranty and liability – Information in this document is believed to be accurate and reliable. Pole/Zero and its suppliers disclaim all warranties, whether express or implied, including implied warranties of merchantability, fitness for a particular purpose, and non-infringement. The entire risk arising out of use or performance of this information remains with Licensee. Pole/Zero and its suppliers do not make any representations regarding the results of the use of the information in this document.

To the maximum extent permitted by applicable law, in no event will Pole/Zero or its directors, employees, distributors, licensors, suppliers, agents or resellers or suppliers (“Pole/Zero parties”) be liable for any indirect, special, incidental, consequential, or exemplary damages, even if such party has been advised of the possibility thereof. The Pole/Zero parties’ entire liability will not exceed the sum of the replacement of defective product or provision of a reasonably similar product, at Pole/Zero’s discretion. Some jurisdictions do not allow the exclusion or limitation of incidental, consequential or special damages, so this exclusion and limitation may not be applicable to Licensee. The Pole/Zero Parties will not be liable for any claims or damages arising out of content provided by Licensee.

10.2 Right to Make Changes

Pole/Zero Corporation reserves the right to make changes to information published in this document, including without limitation specifications and product descriptions, at any time and without notice. This document supersedes and replaces all information supplied prior to the publication hereof.

11.0 Learn More

For additional information, please visit <http://www.dovermpg.com/polezero>.

12.0 Contact and Support

Pole/Zero Corporate Office
5558 Union Centre Drive
West Chester, OH 45069, USA
513-870-9060 (Phone)
513-870-9064 (Fax)